



US007521857B2

(12) **United States Patent**
Kang et al.

(10) **Patent No.:** **US 7,521,857 B2**
(45) **Date of Patent:** **Apr. 21, 2009**

(54) **ORGANIC ELECTRO LUMINESCENT DISPLAY AND METHOD FOR FABRICATING THE SAME**

6,936,846 B2 8/2005 Koyama et al.
6,946,789 B2 9/2005 Ikeda

(75) Inventors: **Tae-Min Kang**, Suwon-si (KR);
Myung-Won Song, Suwon-si (KR);
Seong-Taek Lee, Suwon-si (KR);
Jin-Woo Park, Yongin-si (KR); **Hun Kim**, Seoul (KR)

(Continued)

FOREIGN PATENT DOCUMENTS

JP 2000-352717 12/2000

(73) Assignee: **Samsung Mobile Display Co., Ltd.**,
Suwon-si, Gyeonggi-do (KR)

(*) Notice: Subject to any disclaimer, the term of this patent is extended or adjusted under 35 U.S.C. 154(b) by 0 days.

(Continued)

OTHER PUBLICATIONS

(21) Appl. No.: **11/512,091**

Office Action from the Korean Intellectual Property Office issued in Applicant's corresponding Korean Patent Application No. 10-2003-0040808 dated Mar. 31, 2005 (*with English language translation*).

(22) Filed: **Aug. 30, 2006**

(65) **Prior Publication Data**

US 2006/0290273 A1 Dec. 28, 2006

(Continued)

Primary Examiner—Ashok Patel

(74) *Attorney, Agent, or Firm*—Robert E. Bushnell, Esq.

(51) **Int. Cl.**
H05B 33/00 (2006.01)

(57) **ABSTRACT**

(52) **U.S. Cl.** **313/504**; 313/113; 313/503;
313/506; 313/512

(58) **Field of Classification Search** 313/503–506,
313/509, 512, 113, 292
See application file for complete search history.

An organic electro luminescent display with auxiliary layers on a cathode contact and an encapsulating junction region to easily remove polymer organic layers of the junction and a method for fabricating the same. The organic electro luminescent display has the first electrode formed on a lower insulating substrate, a pixel defining layer formed to make some portions of the first electrode opened over the entire surface of the lower insulating substrate, an organic emission layer formed on an opening of the first electrode, the second electrode formed on the organic emission layer, an upper substrate for encapsulating the first electrode, the organic emission layer and the second electrode, and auxiliary layers formed on the cathode contact and the encapsulating junction region of the lower insulating substrate.

(56) **References Cited**

U.S. PATENT DOCUMENTS

5,800,625 A	9/1998	Engelsberg	
5,814,156 A	9/1998	Elliott	
5,882,487 A	3/1999	Li	
5,958,268 A	9/1999	Engelsberg	
6,033,484 A	3/2000	Mahoney	
6,133,693 A *	10/2000	Keyser	313/506
6,489,590 B2	12/2002	Livshits et al.	
6,639,359 B1 *	10/2003	Chae	313/506
6,641,933 B1	11/2003	Yamazaki et al.	
6,894,431 B2	5/2005	Yamazaki et al.	

18 Claims, 15 Drawing Sheets

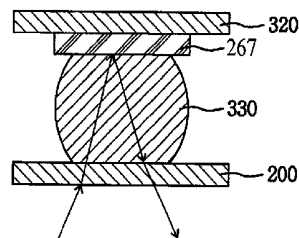
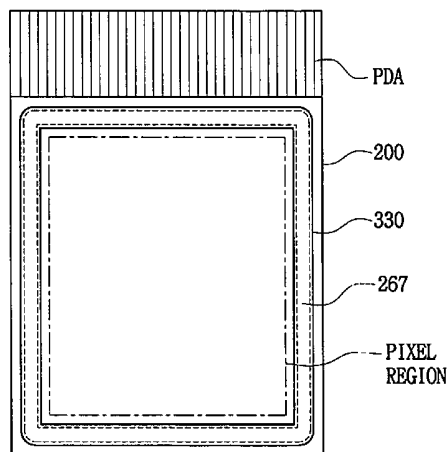

US 7,521,857 B2

Page 2

U.S. PATENT DOCUMENTS

7,012,367 B2 3/2006 Seki
7,067,985 B2* 6/2006 Adachi 315/169.3
2003/0062829 A1 4/2003 Heimgartner
2003/0194484 A1 10/2003 Yamazaki et al.

FOREIGN PATENT DOCUMENTS

KR 2000-0036020 6/2000
KR 10-2001-0044613 6/2001
KR 10-2002-0064028 8/2002
KR 10-2002-0083371 11/2002

KR 10-2002-0083578 11/2002
KR 10-2003-0027305 4/2003

OTHER PUBLICATIONS

The Office Action from the Chinese Patent Office issued in Applicant's corresponding Chinese Patent Application No. 200410035079.8 dated Jan. 4, 2008.

Zhigilei et al., "Microscopic Mechanism of Laser Ablation of Organic Solids in the Thermal and Stress Confinement Irradiation Regimes," *Journal of Applied Physics*, vol. 88, Aug. 1, 2000, pp. 1281-1297.

* cited by examiner

FIG. 1

BFE/PEDOT on SiNx/Glass

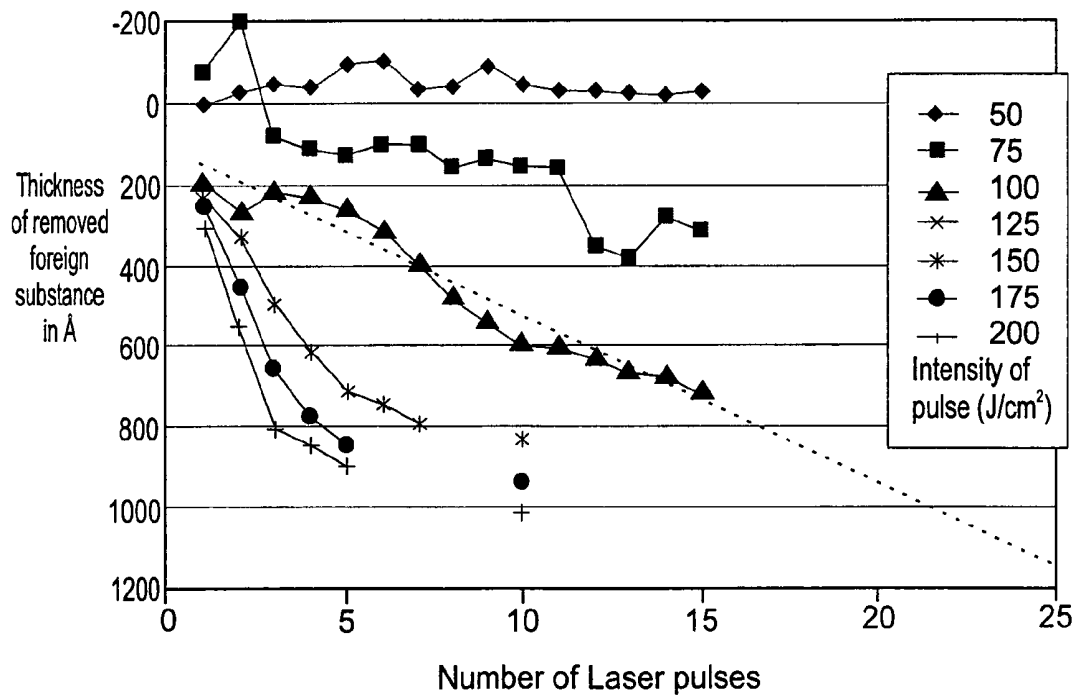

Laser Removal of Organic Emission Layer 150
absent Auxiliary Layers 120/130

FIG. 2
(PRIOR ART)

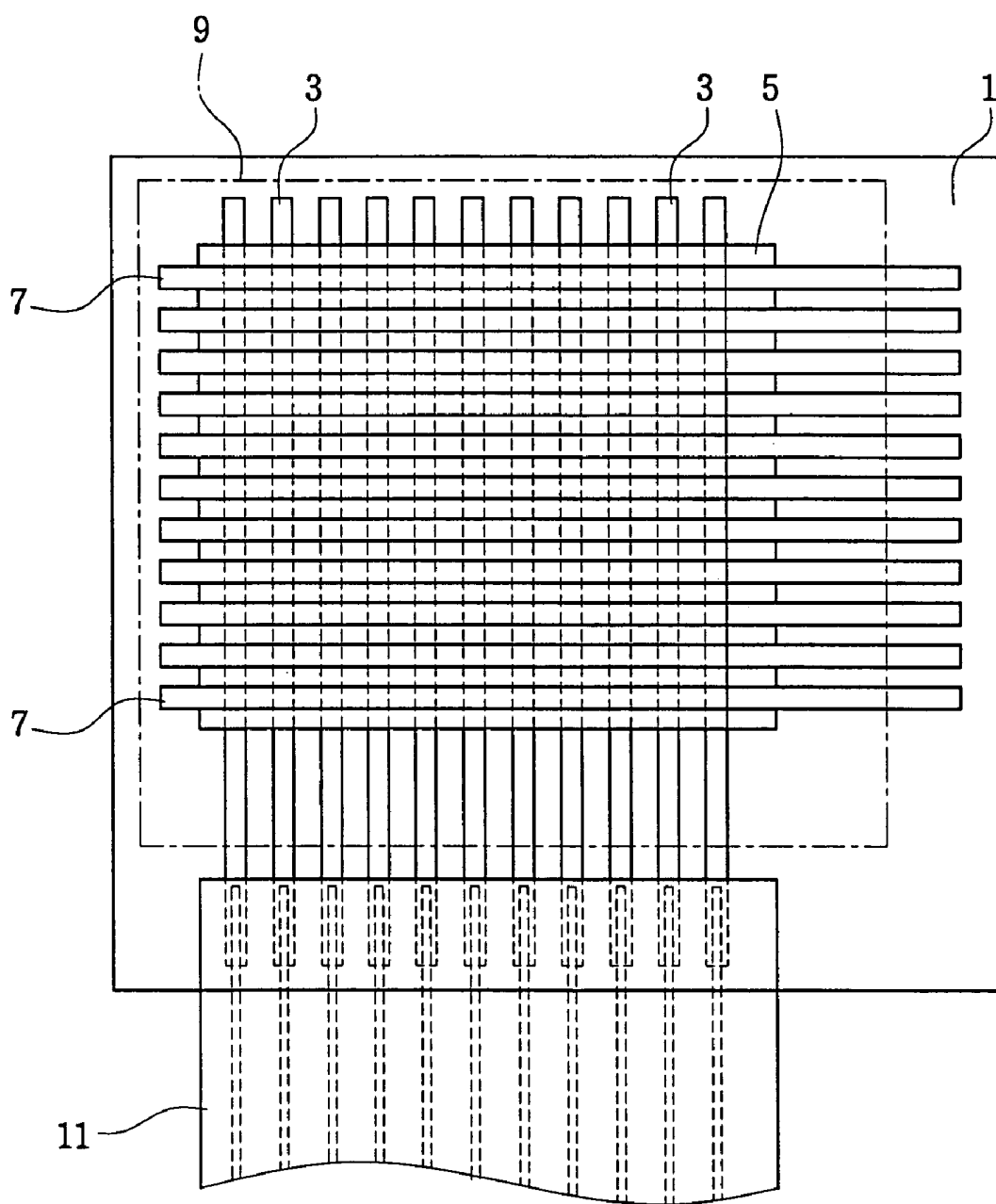

FIG. 3

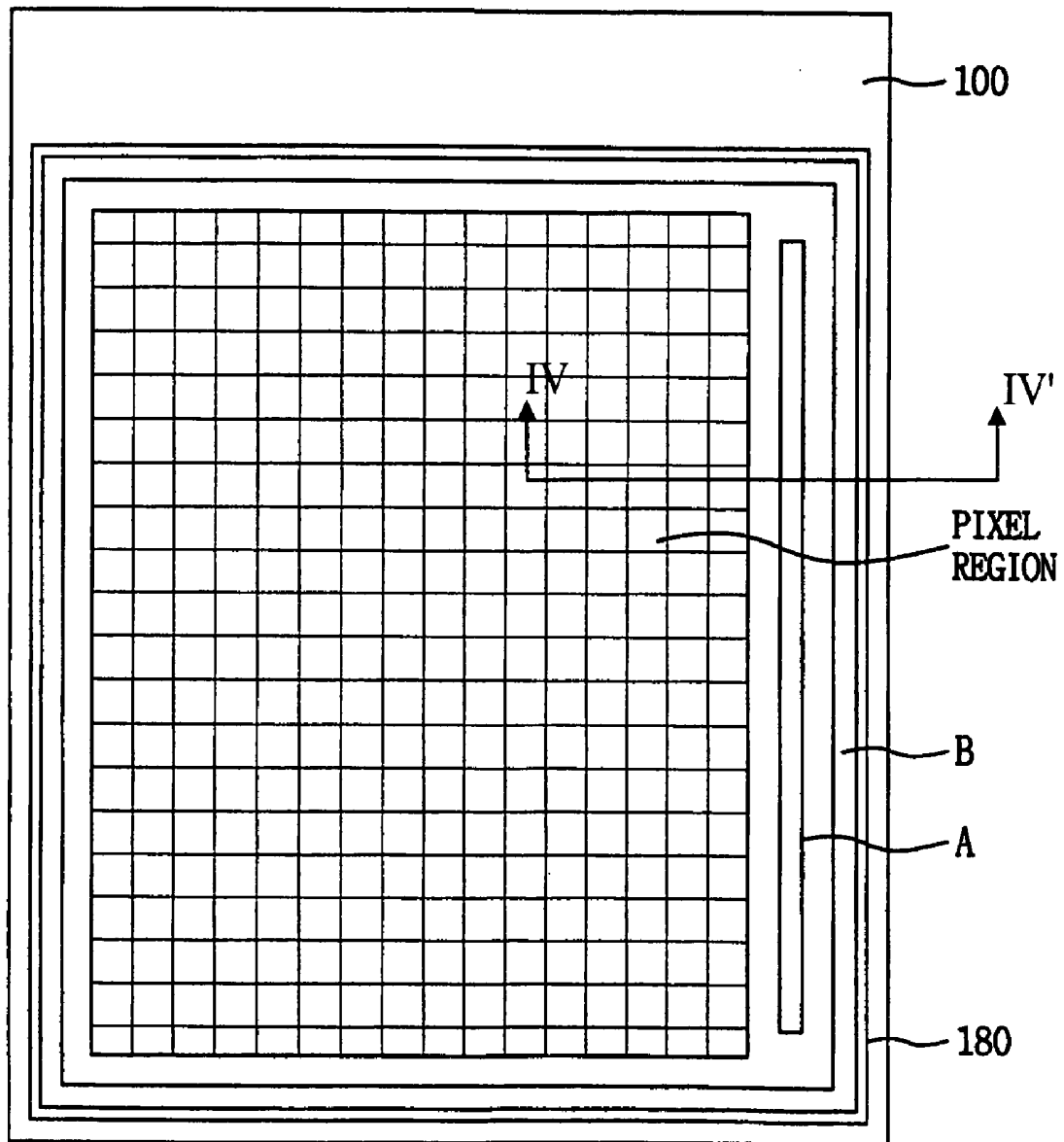

FIG. 4A

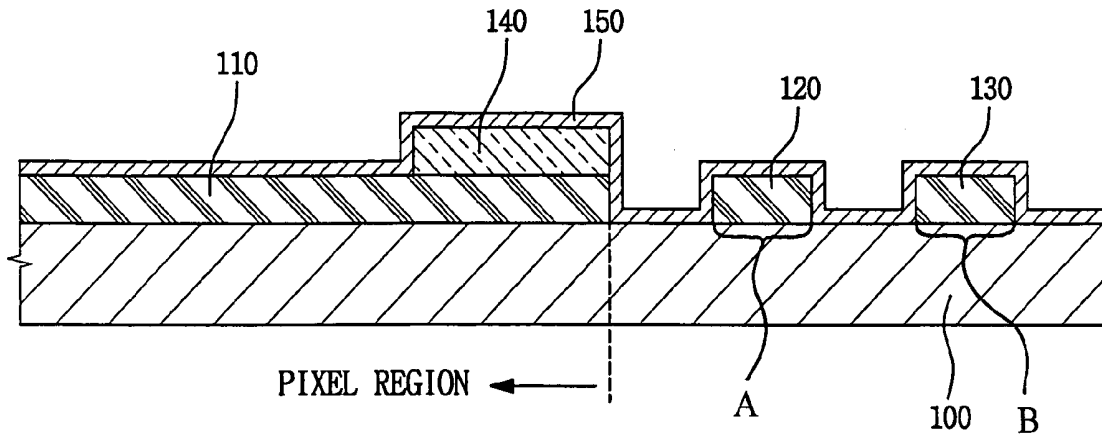

FIG. 4B

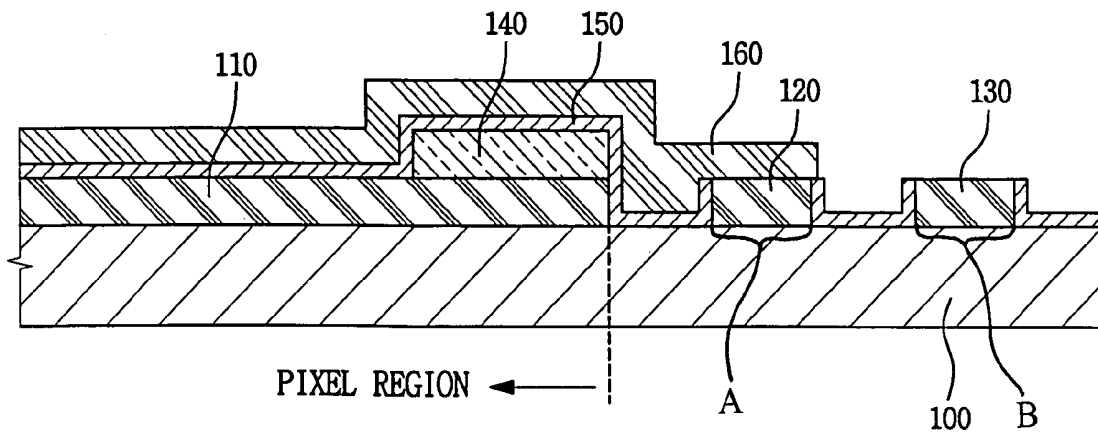

FIG. 4C

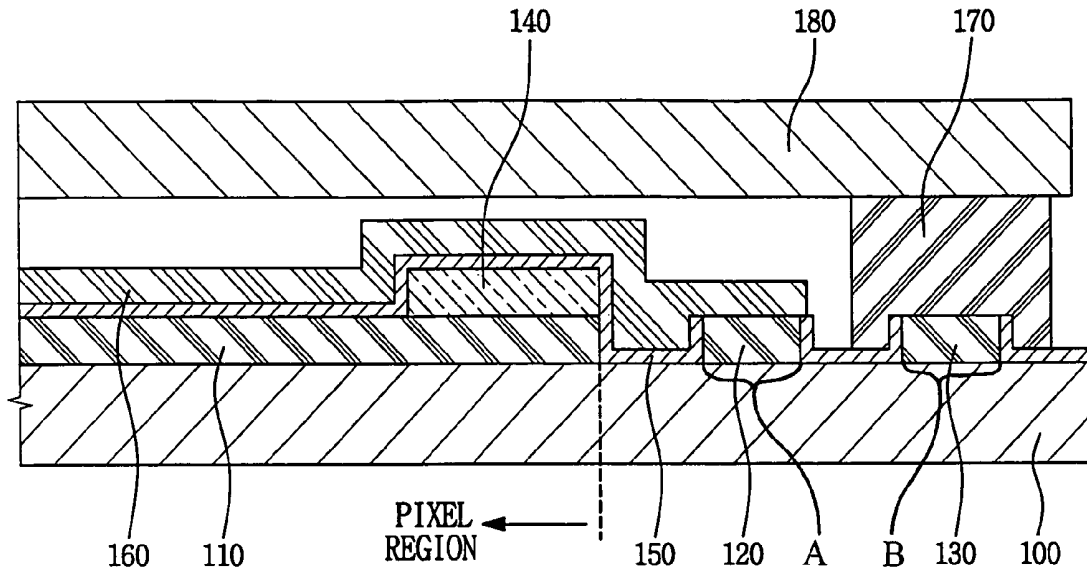

FIG. 4D

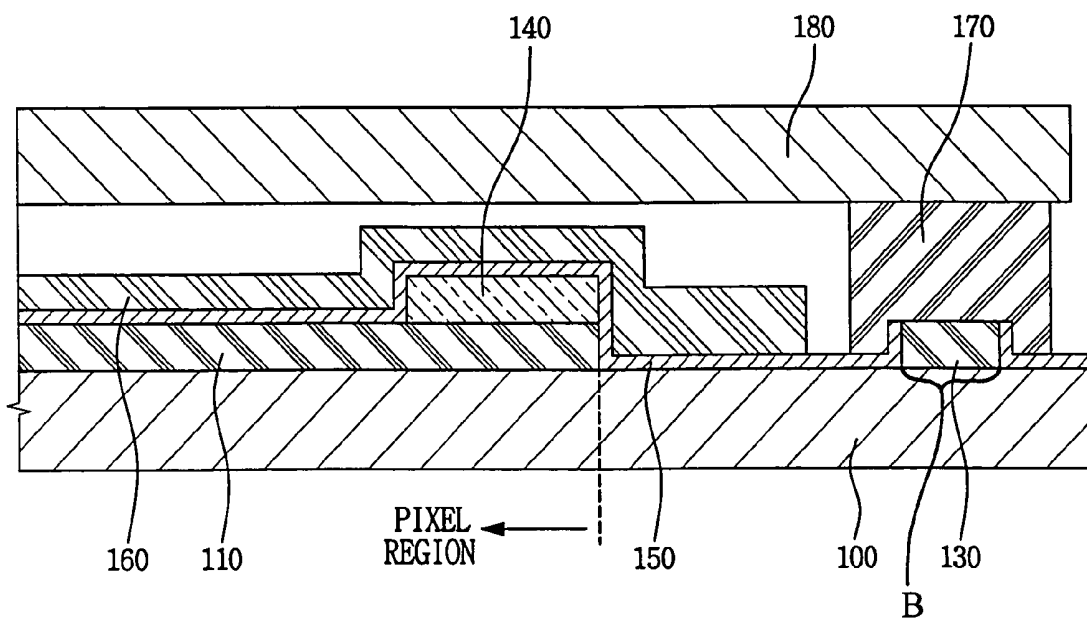
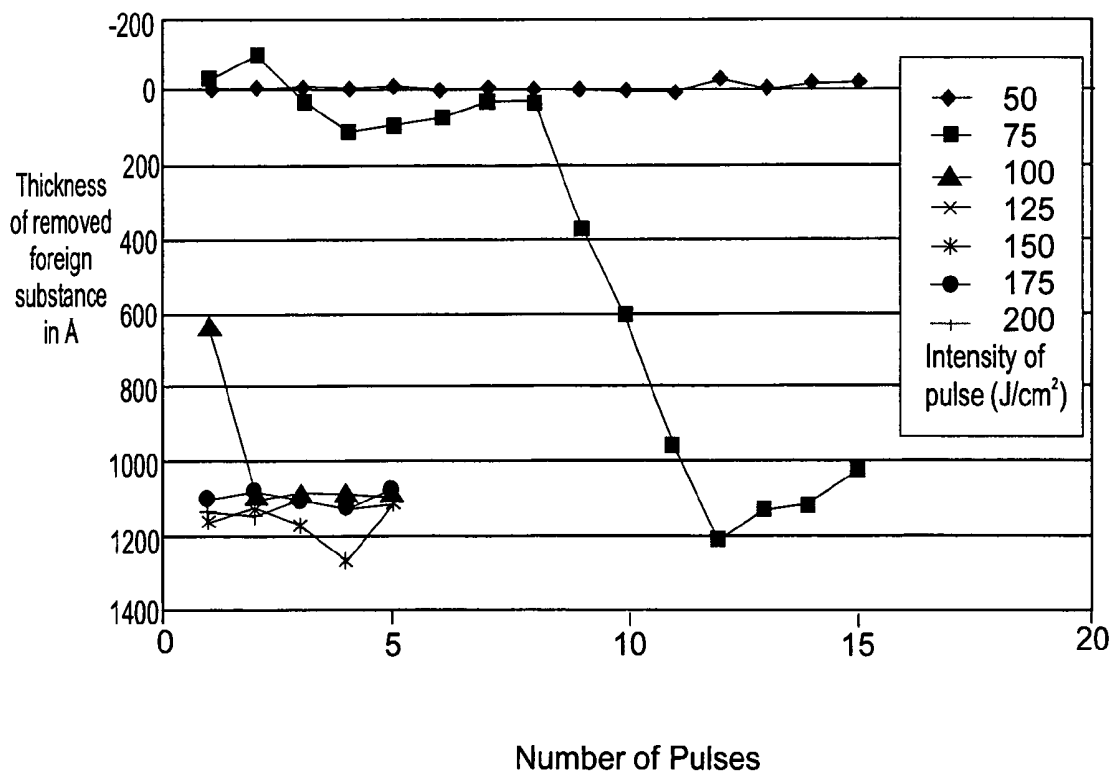

FIG. 5

BFE/PEDOT on ITO/Glass



Laser Removal of Organic Emission Layer 150 on Auxiliary Layers 120/130

FIG. 6A

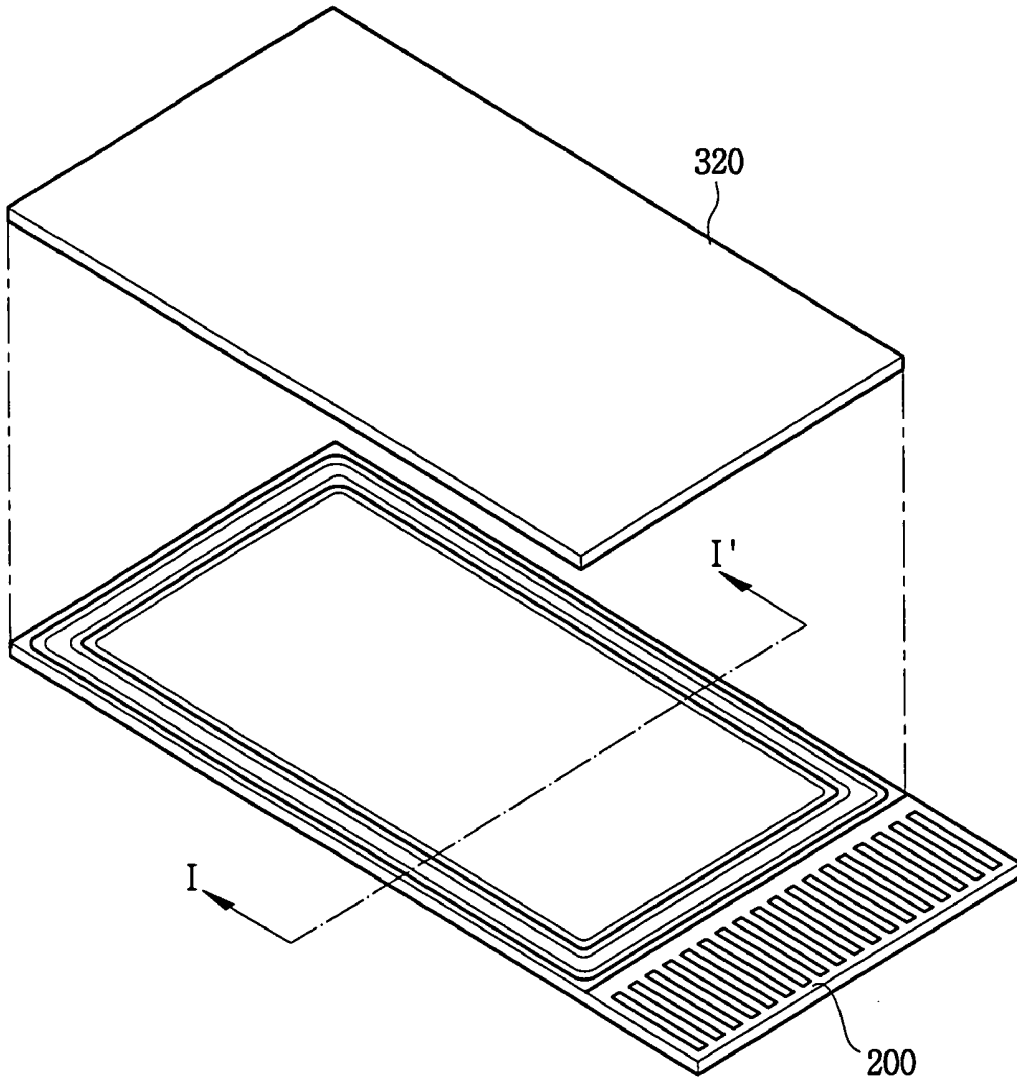

FIG. 6B

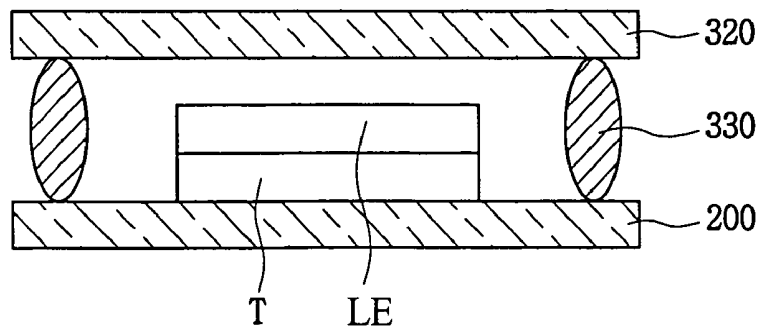

FIG. 7

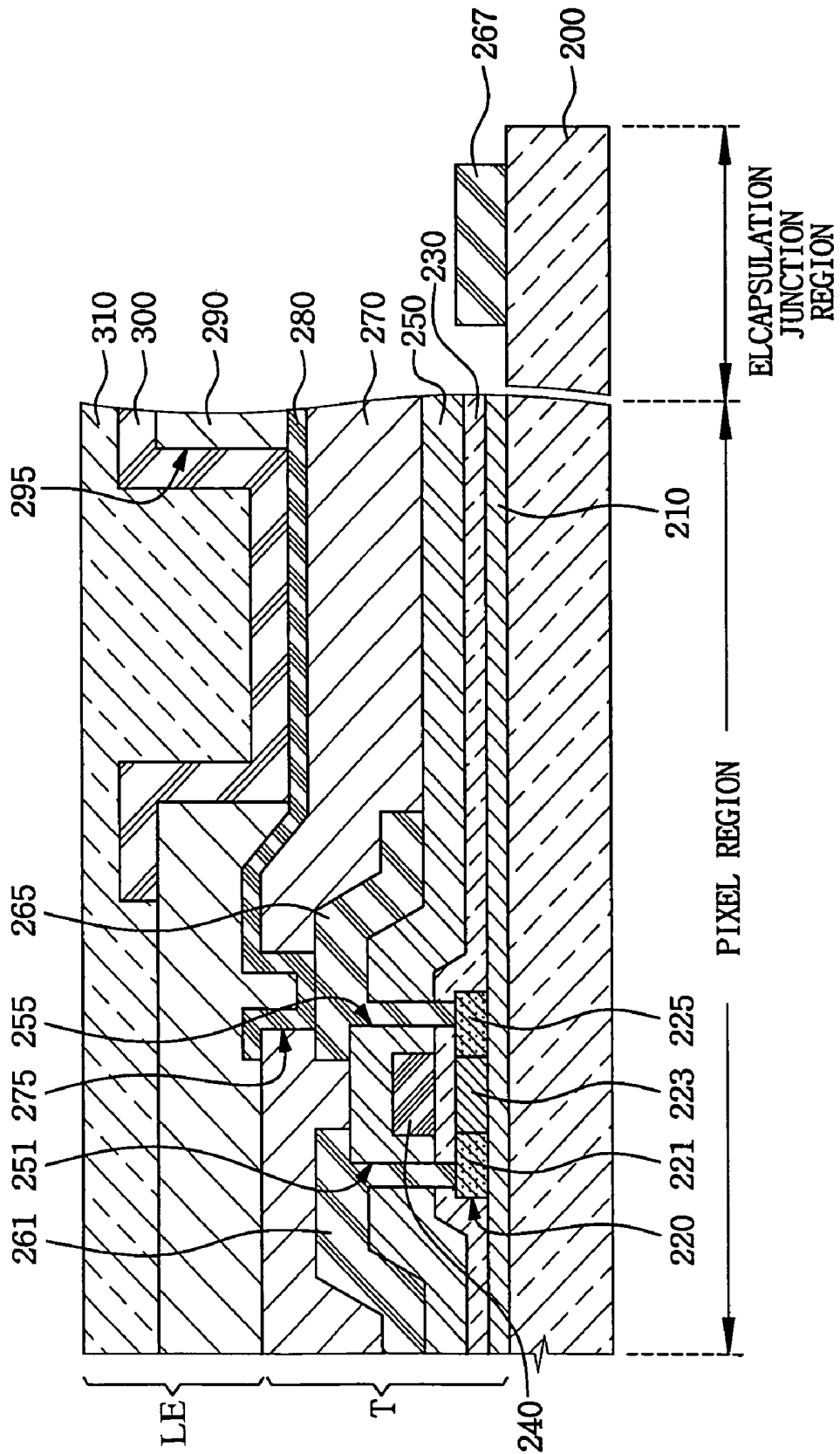

FIG. 8

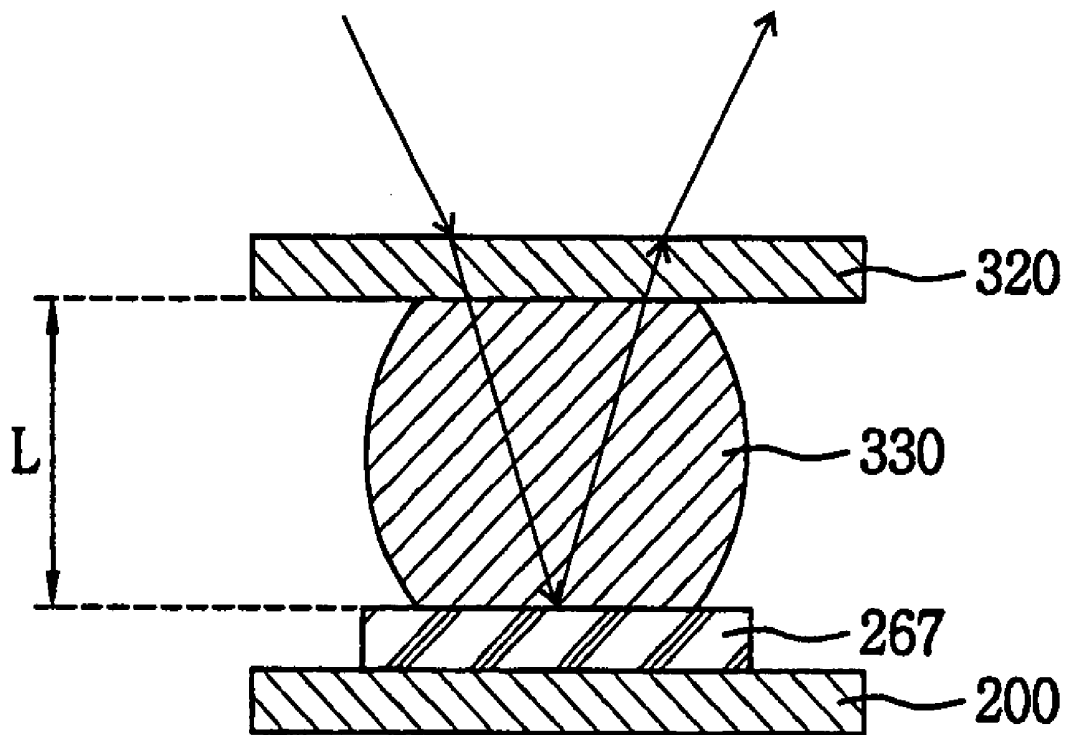

FIG. 9

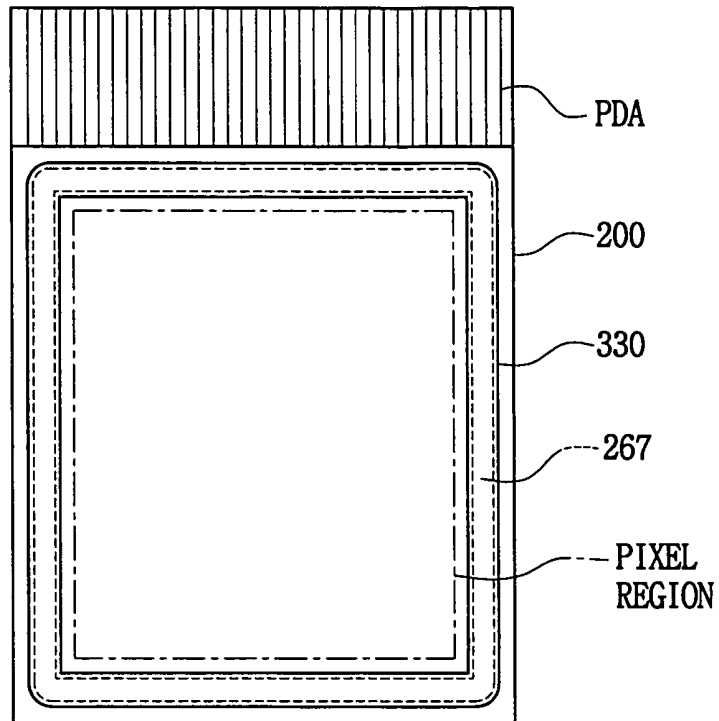

FIG. 10

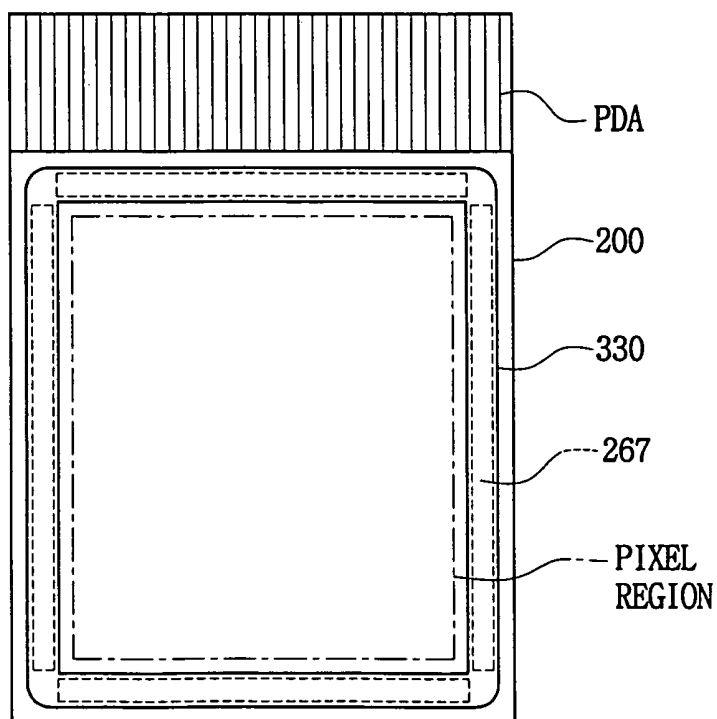

FIG. 11

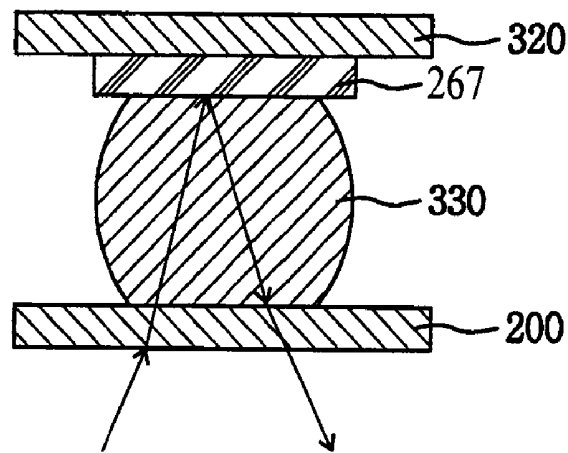

FIG. 12

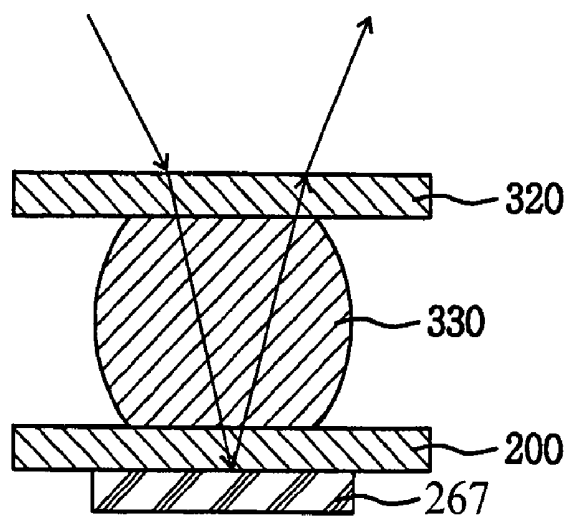

FIG. 13

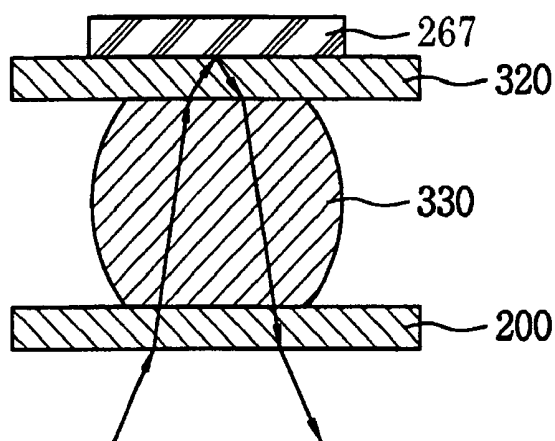

FIG. 14A

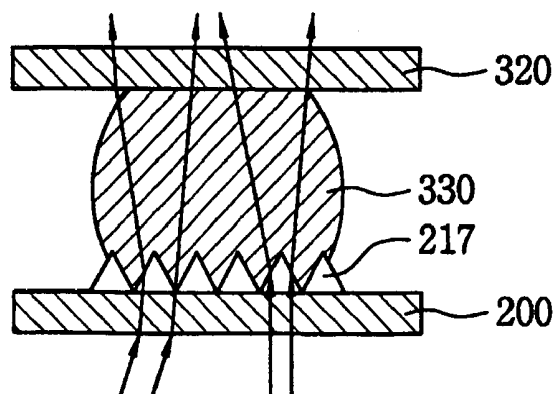

FIG. 14B

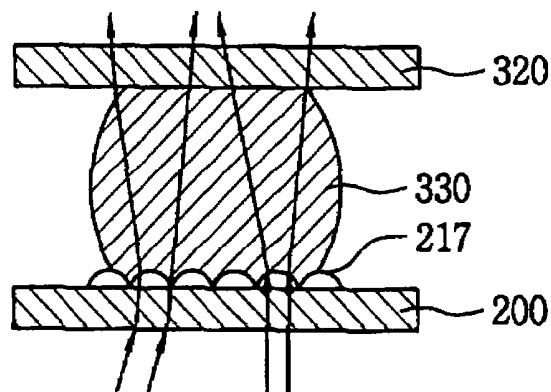

FIG. 15A

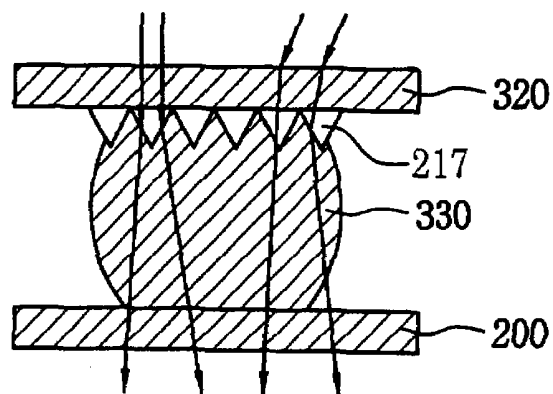

FIG. 15B

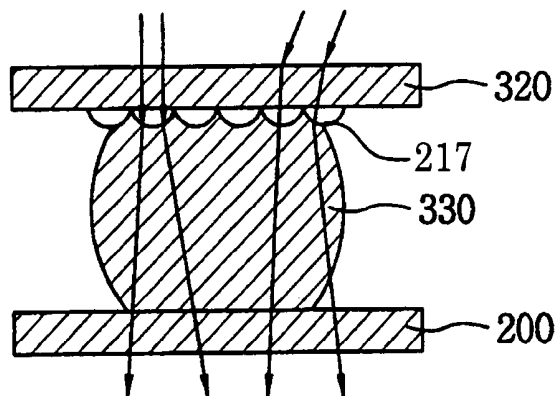

FIG. 16A

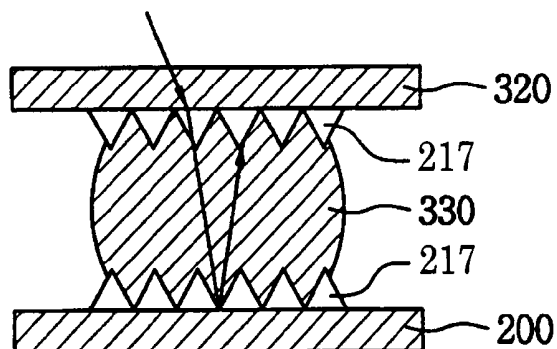
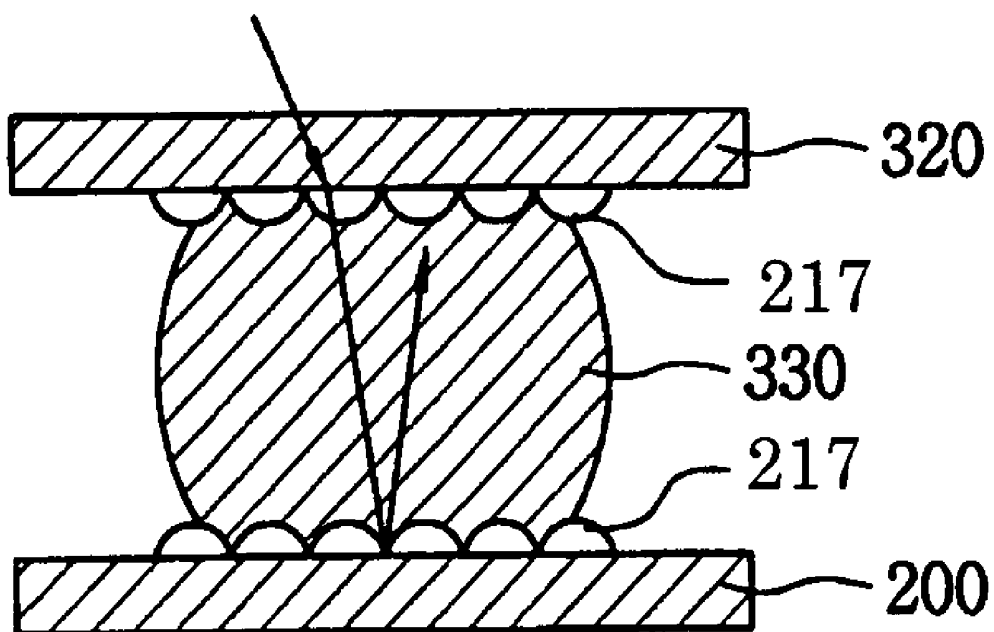

FIG. 16B



**ORGANIC ELECTRO LUMINESCENT
DISPLAY AND METHOD FOR FABRICATING
THE SAME**

CLAIM OF PRIORITY

This application claims priority to an application entitled "ORGANIC ELECTRO LUMINESCENCE DISPLAY AND METHOD FOR FABRICATING THE SAME", filed in the Korean Intellectual Property Office on 10 Jun. 2003 and assigned Ser. No. 2003-37244, and filed on 23 Jun. 2003 and assigned Ser. No. 2003-40808, and filed on 2 Sep. 2003 and assigned Ser. No. 2003-61163, the contents of which are hereby incorporated by reference.

BACKGROUND OF THE INVENTION

1. Field of the Invention

The invention relates to an organic electro luminescent display and a method for fabricating the same and, more particularly, to an organic electro luminescent display having an auxiliary layer encapsulating junction region and a method for fabricating the same.

2. Description of the Related Art

Generally, an organic electro luminescent display is an emissive display capable of emitting light by electrically exciting a fluorescent or phosphorescent organic compound, and phosphorescent organic compound can be driven by a low voltage and has a thin form-factor, a wide viewing angle and a fast response speed, so that the electro luminescent display can solve problems that have been found in liquid crystal displays. Therefore, the electro luminescent display has attracted attention as a next-generation display.

Such an organic electro luminescent display has a structure that has an organic light emitting diode (OLED) including an organic layer having at least emission layer (EML), an anode, and a cathode, wherein the organic layer having a predetermined pattern is formed on a glass or other transparent insulating substrate, and the anode and cathode electrodes are formed on upper and lower portions of the organic layer for applying a driving voltage to the organic layer. The organic layer consists of organic compounds.

In the organic electro luminescent display having the above-mentioned basic structure, as an anode electrode and a cathode electrode voltages are applied to the electrodes, holes injected from the electrode that have been applied with the anode electrode voltage are transported to the emission layer (EML) through a hole transporting layer (HTL), and electrons are injected from the electrode that have been applied with the cathode electrode voltage are transported to the emission layer (EML) through an electron transporting layer (ETL). The electrons and holes are then recombined in the emission layer (EML) to create excitons, and the excitons are then changed from an exciting state to a ground state, thereby emitting an organic substance of the emission layer (EML) and embodying a required image.

In the above-mentioned organic electro luminescent display, when a polymer material is used for the organic layer, the organic layer is generally formed on a substrate by spin coating. However, when the organic layer is formed by the spin coating, the organic layer is also formed in regions other than the pixel portion. Thus, the organic layer of the encapsulating junction region needs to be removed to encapsulate an inner structure of the organic electro luminescent display.

In a prior art, a cleaning process using an organic solvent was performed to remove the organic layer of the encapsulating junction region, however, the process has a signifi-

cantly low accuracy and the organic solvent often penetrates into the pixel portion, so that there is a high possibility of damaging the pixel portion.

To solve the above-mentioned problems, a method using a laser is disclosed to remove a foreign substance including organic emissive materials off a substrate. According to a Korean laid-open Patent Application No. 2000-0036020, a method for removing the foreign substance using the laser is disclosed. This method removes organic or inorganic foreign substances on the substrate by directly irradiating the ultraviolet laser on the surface of the substrate.

In the case of the substrate of the prior art, a metal wiring and a passivation layer are usually deposited on a glass substrate in the encapsulating junction region. However, the laser energy absorption rate of the passivation layer is small so that the organic layer is not easily removed by using a laser.

SUMMARY OF THE INVENTION

It is therefore an object of the present invention to provide for an improved design for an electro luminescent display.

It is also an object of the present invention to provide for a novel method for making an electro luminescent display.

It is further an object of the present invention to provide for a novel structure of an electro luminescent display that allows for easier selective removal of an organic emissive layer using a laser.

It is yet another object of the present invention to provide a novel method of making an electro luminescent display that more efficiently selectively removes unwanted materials using a laser without destroying other portions of the electro luminescent display.

It is further an object of the present invention to provide a novel structure for an electro luminescent display that allows for sealant to be efficiently cured by ultraviolet light while preventing other parts of the electro luminescent display from being harmed by the curing ultraviolet light.

It is further an object of the present invention to provide a novel method for making an electro luminescent display that allows for sealant between the substrates and between the electrodes to be efficiently sealed by ultraviolet light where other portions of the display are not harmed by exposure to the curing ultraviolet light.

These and other objects can be achieved by an organic electro luminescent display, which has the first electrode formed on a lower insulating substrate, a pixel defining layer formed to make some portions of the anode electrode opened over the entire surface of the lower insulating substrate, an organic layer formed on an opening of the anode electrode, the second electrode formed on the organic layer, an upper substrate for encapsulating the anode electrode, the organic layer and the cathode electrode, and auxiliary layers formed on a cathode contact and an encapsulating junction region of the lower insulating substrate. The organic layer is deposited over the first electrode and the auxiliary layers. The organic layer is selectively removed by laser from the auxiliary layers. The material for the auxiliary layers are carefully chosen so that the organic layers can be removed from the auxiliary layers with relatively little amount of laser light.

The present invention also includes a method for making the electro luminescent display having the auxiliary layers and the application of laser light to remove the organic layers off the auxiliary layers via laser ablation.

The invention separately provides a novel structure for an organic electro luminescent display. The novel display is made up of upper and lower substrates bounded to each other by an ultraviolet light curable sealant. The sealant is placed

around the pixel region in an encapsulation region. A reflecting plate is placed adjacent to the sealant. The reflecting plate is used to reflect the ultraviolet light so that less light is needed to cure the sealant. Less light or more efficient use of the ultraviolet light means that the other parts of the electro luminescent display are not degraded or damaged due to exposure to an excessive amount of ultra violet light. The sealant and the reflecting plate can be used in either active or passive matrix pixel structures. In place of the reflecting plate, a waveguide can be used adjacent to the sealant.

The present invention also pertains to a method of making the above structure for an electro luminescent display including the application of the reflective plate and/or waveguide and the ultraviolet curing step.

BRIEF DESCRIPTION OF THE DRAWINGS

A more complete appreciation of the invention, and many of the attendant advantages thereof, will be readily apparent as the same becomes better understood by reference to the following detailed description when considered in conjunction with the accompanying drawings in which like reference symbols indicate the same or similar components, wherein:

FIG. 1 is a graph illustrating empirically a relationship between application of laser energy versus removal of an organic layer absent the use of auxiliary layers under the organic layer;

FIG. 2 is a plane view for explaining an organic electro luminescent display;

FIG. 3 is a plane view showing an organic electro luminescent display according to the first three embodiments of the present invention;

FIGS. 4A to 4D are cross-sectional views illustrating the process of making the display of FIG. 3 according to a first embodiment of the present invention;

FIG. 5 is a graph illustrating empirically a relationship between application of laser energy versus removal of an organic layer when the organic layer is formed over the auxiliary layers according to the present invention;

FIG. 6A is an exploded perspective view showing an organic electro luminescent display according to a fourth embodiment of the invention;

FIG. 6B is a cross-sectional view of the display of FIG. 6A taken along the I-I';

FIG. 7 is a view illustrating both a pixel region for an active matrix pixel and an encapsulating junction region according to the fourth embodiment of the invention;

FIG. 8 is a cross sectional view of the encapsulation junction region according to the fourth embodiment of the present invention where a reflection plate is on an inside side of the lower insulating substrate;

FIGS. 9 and 10 are plane views for explaining an arrangement of a reflection plate vis-a-vis the sealant and the pixel region according to the fourth embodiment of the present invention;

FIG. 11 illustrates a cross section of an encapsulation junction region according to a fifth embodiment of the present invention where the reflection plate is on an inside side of the upper substrate;

FIG. 12 illustrates a cross section of an encapsulation junction region according to a sixth embodiment of the present invention where the reflection plate is on an outside side of the lower insulating substrate;

FIG. 13 illustrates a cross section of an encapsulation junction region according to a seventh embodiment of the present invention where the reflection plate is on an outside side of the upper substrate;

FIGS. 14A and 14B illustrate a cross section of an encapsulation junction region according to an eighth embodiment of the present invention where a wave guide is located on an inside side of the lower insulating substrate;

FIGS. 15A and 15B illustrate a cross section of an encapsulation junction region according to a ninth embodiment of the present invention where a wave guide is located on an inside side of the upper substrate; and

FIGS. 16A and 16B illustrate a cross section of an encapsulation junction region according to a tenth embodiment of the present invention where there are two wave guides present, one on an inner surface of the upper substrate and another on the inner surface of the lower insulating substrate.

DETAILED DESCRIPTION OF THE INVENTION

Turning now to FIG. 1, FIG. 1 illustrates empirical results for thickness of removed foreign substance based on number of laser pulses applied and the energy of each pulse. As illustrated in FIG. 1, as the number of laser pulses increases, the amount or thickness of removed foreign substances does not increase in a linear fashion with the number of laser pulses applied. For example, as the thickness of the remaining organic layers becomes thinner, the removal rate per additional laser pulse decreases, so that a significant amount of energy and a large number of laser pulses are required to completely remove the residual substances. Because a large number of laser pulses at a high energy per pulse is needed to completely remove the foreign substance, the laser may cause damage to the substrate in the foreign substance removal process.

In addition to the removal of foreign substances by a laser, in the organic electro luminescent display of the prior art, a sealant is used to join the substrates together. An upper substrate is bound to a lower insulating substrate via this sealant. The sealant also serves to encapsulate organic electro luminescent elements and plays a role in determining a lifetime, efficiency, etc. of the organic electro luminescent elements.

The organic electro luminescent element mainly is divided into an inner pixel portion that actually emits light and a pad portion for connecting an external driving IC for driving the pixel portion, wherein the driving portion and the pad portion are connected by a wiring made of opaque metals to minimize resistance. In this case, an encapsulating process using a sealant is performed to prevent moisture and air from an outside of a display from coming into contact with and destroying the organic electro luminescent element. The sealant is ordinarily cured by exposure to light, especially ultraviolet light. However, when the lower insulating substrate is attached to and encapsulated by the upper substrate using the ultraviolet cured sealant, it takes more time to cure the sealant using the ultraviolet light. Because an immense amount of ultraviolet light is needed to cure the sealant, the ultraviolet light can damage other portions of the display, either by heating parts up or causing an unwanted chemical reaction in the display. If the amount of ultraviolet light used to cure the sealant is reduced to prevent the damage to other parts of the display, the sealant will not be fully cured because the sealant has not received adequate exposure to the ultraviolet light to fully cure.

Turning now to FIG. 2, FIG. 2 illustrates an organic electro luminescent display of the prior art (FIG. 5 of Korean laid-open Patent Application No. 2000-0036020). The process used to form the display of FIG. 2 will now be described. A plurality of first electrodes 3 made of optically transmissive materials are formed in an arbitrary pattern, such as a stripe pattern, over one surface of a lower insulating substrate 1.

Lower insulating substrate **1** is made out of a material that is both electrically insulating and optically transmissive. An insulating layer **5** is formed on the first electrodes **3**, and a plurality of second electrodes **7** are formed on insulating layer **5** in a stripe pattern to a direction orthogonal to the first electrodes **3**.

In this case, pixel portions of the organic electro luminescent display are where the first electrodes **3** and the second electrodes **7** are cross each other. Where second electrodes **7** and first electrodes **3** cross each other, the insulating layer **5** in these crossed regions is not present. Instead, a thin organic layers disposed in these cross over regions. The organic emissive material (not illustrated in FIG. **2**) is also in electrical contact with both the first electrodes **3** and the second electrodes **7** in the cross over areas.

In this case, an upper substrate **9** (illustrated as a dotted line in FIG. **2**) is disposed over a lower substrate **1**, and the lower substrate **1** and the upper substrate **9** are bound to each other by a sealant that is not illustrated in FIG. **2**, so that the organic electro luminescent display of FIG. **2** is formed.

According to the above-mentioned structure of FIG. **2**, some portions of the first electrodes **3** and the second electrodes **7** are exposed outside the substrates **1** and **9** so that electrodes **3** and **7** can be electrically connected to circuit driving elements, for example FPC (Flexible Printed Circuit, **11**). Circuit **11** is electrically connects external equipment to the organic electro luminescent display by thermal compression, etc.

However, in the organic electro luminescent display having the above-mentioned structure, the process of applying and curing the sealant is not properly performed when the lower substrate **1** and the upper substrate **9** are sealed together, thereby decreasing the lifetime and reliability of the product. In the typical prior art, a sealing material is applied along the periphery of the lower substrate **1** as described above and the upper substrate **9** is mounted thereon, and ultraviolet rays are irradiated from the rear surface of the lower substrate **1** and the sealing material is cured, so that the lower substrate **1** and the upper substrate **9** are bonded together.

When the ultraviolet rays irradiate the sealing material disposed in a portion of the display that is exposed outside the first and second electrodes **3** and **7** on the substrates **1** and **9** (i.e., the lower and right sides of FIG. **2**), the sealing material was cured without any significant problems because the ultraviolet light was not blocked or hindered by the electrode layers **3** and **7**. However, when the ultraviolet rays irradiate the sealing material disposed in a portion of the display where the striped patterns of electrode layers **3** and **7** are present (i.e., the upper and the left sides in FIG. **2**) the presence of the electrode layers **3** and **7** hinders the ultraviolet rays from effectively reaching the sealant between the substrates **1** and **9** thus requiring more pulses and/or higher energy pulses to fully cure the sealant in these regions of the display. If the sealant is not properly cured by an adequate exposure to ultraviolet light, air and moisture will then be allowed to penetrate through the sealant and into the emissive layers to cause deterioration of a display.

The present invention has **10** embodiments. The first three embodiments concentrate on the auxiliary layers in both structure and in method of making. Organic layers on top of the auxiliary layers are more easily removed via exposure to a laser than if the auxiliary layers were not present.

First Embodiment

Turning now to FIG. **3**, FIG. **3** is a plane view illustrating an organic electro luminescent display according to a first

embodiment of the present invention, and FIGS. **4A** to **4D** are cross-sectional views illustrating a process for making the organic electro luminescent display of FIG. **3** according to an embodiment of the present invention.

Referring to FIG. **4A**, a first electrode (or anode electrode) **110** is deposited on substrate (or lower substrate) **100**. First electrode is made out of a transparent and conductive material such as ITO (indium tin oxide), IZO (indium zinc oxide) or ICO (indium cesium oxide). This transparent first electrode material is deposited and patterned on the lower insulating substrate **100**, and a transparent anode electrode, in other words, the first electrode **110** formed in the pixel portion. Lower substrate **100** may be a transparent substrate made out of an electrically insulating material, such as glass.

In the first embodiment, the auxiliary layers **120** and **130** are made out of the same material as the first electrode **110**. Therefore, the auxiliary layers **120** and **130** are deposited and patterned on lower substrate **100** at the same time as when the first electrode **110** is deposited and patterned on lower substrate **100**. Auxiliary layer **120** is formed at cathode contact A while auxiliary layer **130** is formed at encapsulating junction region B.

After forming the auxiliary layer **130** on the encapsulating junction region B, the auxiliary layer **120** on the cathode contact A, and the anode **110** of the pixel portion, a pixel defining layer **140** is deposited and patterned on first electrode **110** covering parts of first electrode **110** and leaving other parts of the top surface of first electrode exposed. The pixel defining layer **140** is preferably an inorganic material and a polymer such as an acrylic photoresist or a polyimide.

Next, the organic layer **150** is deposited to cover the pixel defining layer **140**, the exposed portions of the first electrode **110**, the auxiliary layers **120** and **130**, and over exposed portions of lower substrate **100**. The organic layer **150** is preferably formed by spin coating. The organic emission layer **150** preferably includes at least an emission layer (EML) and has a multi-layered structure made up of at least one of a hole injection layer (HIL), a hole transporting layer (HTL), an emission layer (EML), an electron transporting layer (ETL), and an electron injection layer (EIL).

Referring now to FIG. **4B**, after forming the organic layer **150**, the organic layers on the auxiliary layers **120** and **130** over cathode contact A and the encapsulating junction region B of the substrate are removed. The process of selectively removing the organic layers **150** from the auxiliary layers **120** and **130** is preferably accomplished by exposing these portions of organic layers **150** with light pulses from a laser. This process of removing the organic layers **150** using a laser is called laser ablation. In addition, a type of the laser can be selected from an UV based one (Excimer laser, Nd: YAG laser, etc) to an IR based one (Nd: YAG, CO₂ laser, etc) according to a material of a light source.

After removing the organic layers from the tops of the auxiliary layers **120** and **130**, a conductive material is then deposited and patterned on the structure to form the second electrode or cathode electrode **160**. The cathode electrode **160** performs a role of transporting electrons to the electron transporting layer of organic layer **150** by using a metal electrode such as Al, Mg, Ag, Ca that has a low work function.

Referring now to FIGS. **4C** and **4D**, after forming the cathode electrode **160**, an upper substrate **180** is attached to the top of the electro luminescent display using an encapsulating adhesive **170**. The encapsulating adhesive is formed over auxiliary layer **130** which is over encapsulating junction region B of lower substrate **100**. Therefore, encapsulating adhesive **170** is formed around the periphery of the electro luminescent display and surrounds the pixel region.

Referring to FIG. 5, FIG. 5 is a graph illustrating empirically the amount of an organic layer 150 that is removed by a laser based on the number of laser pulses and the energy intensity of each pulse. FIG. 5 is for the scenario of where the organic layers 150 is supported by auxiliary layers 120 and 130. FIG. 5 is to be compared with FIG. 1 which illustrates removal thicknesses of the organic layers when the organic layers 150 are not on top of an auxiliary layer. In the method for removing foreign substances on the substrate 100 where the foreign substances are organic layers on top of an auxiliary layer 120/130, by using the auxiliary layers 120 and 130, the organic layers are more easily removed since less pulses and less intensity is needed to remove the organic layers when they are supported by auxiliary layers 120 and 130. It is to be appreciated that other materials can also be removed by the laser in addition to the organic layers. Therefore, in this specification, foreign substances includes the organic layers but is not limited thereto. Less number of pulses and less intensity of pulses means that the remainder of the electro luminescent display sustains less damage from the laser pulses when auxiliary layers 120 and 130 are used (FIG. 5) compared to when they are not used (FIG. 1).

FIG. 5 illustrates that 12 pulses with an energy intensity of 75 J/cm² can remove the entire organic layer if the organic layer is supported by auxiliary layers 120 and 130. This compares with 25 pulses of 100 J/cm² for when the organic layers are not supported by the auxiliary layers. Because having the auxiliary layers 120 and 130 present allows for the removal of the organic layers with less pulses with less intensity, the other parts of the electro luminescent display sustain less damage when auxiliary layers 120 and 130 are incorporated into the design.

More preferably, a removing depth of the organic layer can be maximized by irradiating the laser with energy density not less than 125 mJ/cm². That is, when the organic layers are removed by using the auxiliary layer and the laser, energy required for removing the organic layers is small.

Second Embodiment

The organic electro luminescent display according to a second embodiment has a similar structure as that of the first embodiment except the material used for the auxiliary layers 120 and 130 is different. In the second embodiment, the material used in the auxiliary layers 120 and 130 is the same as the material used in pixel defining layer 140. Therefore, pixel defining layer 140 and the auxiliary layers 120 and 130 can be formed at the same time. The pixel defining layer and the auxiliary layers are deposited at the same time and the patterning and etching of the pixel defining layer 140 and auxiliary layers 120 and 130 are accomplished in a single step. As discussed previously, the pixel defining layer 140 is preferably an inorganic material and a polymer such as an acrylic photoresist or a polyimide. By having the auxiliary layers 120 and 130 made out of the same material as the pixel defining layer 140, the number of pulses needed and the energy intensity of each pulse to remove the organic layer is reduced from the case of FIG. 1 where no auxiliary layers were present.

Third Embodiment

The organic electro luminescent display according to a third embodiment has a similar structure as that of the first embodiment except that the auxiliary layers 120 and 130 for removing the organic layers 150 are formed by using mate-

rials having a laser energy absorption rate higher than that of the organic layer 150 for the laser wavelength used to remove the organic layer.

That is, after forming the pixel defining layer 140 in the first embodiment, the auxiliary layers 120 and 130 are formed on the cathode contact A and the encapsulating junction region B by depositing and patterning materials having a higher laser energy absorption rate for the laser wavelength used in the removal process

The third embodiment is not necessarily mutually exclusive from the first or the second embodiment. For example, use of ITO, IZO or ICO could result in the auxiliary layer having a higher absorption of the laser light than the organic layer and thus the auxiliary layers 120 and 130 can still be made at the same time as the first electrode 110. Also, use of acrylic photoresist or polyimide for auxiliary layers 120 and 130 may have a higher absorption than organic emission layer 150 and thus the auxiliary layers 120 and 130 can be made at the same time that the pixel defining layer 140 is made.

Now embodiments 4 through 10 will now be discussed. In these embodiments, the focus is on an ultraviolet cured sealant used to fix a top substrate to the bottom substrate. A reflecting plate and/or a wave guide is placed adjacent to the sealant so that the sealant can be cured with less ultraviolet light than if no reflecting plate or waveguide is used. Consequently, by using less ultraviolet light to cure, the remaining parts of the electro luminescent display are subjected to less ultraviolet radiation and thus less damage results.

Fourth Embodiment

Turning now to FIGS. 6A and 6B, FIG. 6A is an exploded perspective view illustrating an organic electro luminescent display according to a fourth embodiment of the invention, and FIG. 6B is a cross-sectional view taken along the I-I' direction of FIG. 6A. Referring to FIGS. 6A and 6B, the organic electro luminescent display of the fourth embodiment of the present invention has a structure that a lower insulating substrate 200 having a pixel portion is bonded to an upper substrate 320 at an encapsulating junction region, the plurality of pixels being located in the pixel portion. That is, in the organic electro luminescent display of the present invention, the pixel portion is formed on the upper side of the transparent lower insulating substrate 200, and can be formed in a typical structure of the organic electro luminescent display. The fourth embodiment can be either a passive matrix or an active matrix using thin film transistors or TFTs.

For example, when the organic electro luminescent display L is formed in a passive matrix (PM) type, the pixel portion is made up of electrode layers corresponding anode and cathode electrodes, respectively, and organic layers having emission layer disposed on positions corresponding to the common portions where the anode and cathode layers cross each other. When the organic electro luminescent display is formed in a active matrix (AM) type, the pixel portion can further include thin film transistors TFTs. The fourth embodiment of the present invention can be applied to any structure with the pixel portion, however, for example, an active matrix organic electro luminescent display will now be described in conjunction with FIG. 7.

Turning now to FIG. 7, FIG. 7 illustrates a cross-sectional view illustrating an active matrix type pixel and an encapsulating junction region according to the fourth embodiment of the present invention. FIG. 8 is a cross-sectional view illustrating an encapsulating junction region of the organic electro luminescent display according to the fourth embodiment of the invention. The organic electro luminescent display

according to the fourth embodiment of the present invention has a structure that includes a reflecting plate 267 adjacent to sealant 330. Reflecting plate 267 and sealant 330 are disposed in the encapsulation portion region of the electro luminescent display. Sealant 330 permanently binds the upper substrate 320 to the lower substrate 200.

Referring to FIGS. 7 and 8, a method for fabricating the organic electro luminescent display having the reflecting plate 267 in the encapsulating junction region will now be described. Referring to FIG. 7, a buffer layer 210 is formed on the lower insulating substrate 200 to prevent impurities such as metal ions diffused from the lower insulating substrate 200 from penetrating to an active layer. After forming the buffer layer 210, amorphous silicon is deposited and crystallized on the buffer layer 210 to form a polycrystalline silicon layer, which is then patterned to form the active layer 220. A gate insulating layer 230 is deposited on all surfaces of the lower insulating substrate 200 containing the active layer, and gate metal is deposited and patterned on the gate insulating layer to form a gate electrode 240.

After forming the gate electrode 240, an impurity having a predetermined conductive type is doped in the active layer by using the gate electrode 240 as a mask to form source/drain regions 221 and 225. A region with no impurity doped between the source region 221 and the drain region 225 acts as a channel region 223. After forming the source/drain regions 221 and 225 on the active layer 220, an interlayer insulating layer 250 is formed over the entire surface of the lower insulating substrate 200, and contact holes 251 and 255 are formed to expose some portions of the source/drain regions 221 and 225 on the interlayer insulating layer 250.

After depositing a conductive material on the interlayer insulating layer 250 including the contact holes 251 and 255, the conductive material is patterned to form source/drain electrodes 261 and 265 connected to the source/drain regions 221 and 225 through the contact holes, thereby forming a TFT (T) consisted of the active layer 220, a gate electrode 240, and the source/drain electrodes 261 and 265, etc.

In this case, when the source/drain electrodes 261 and 265 are formed, a reflecting plate 267 of a metal thin layer consisted of the conductive material is also formed in the encapsulating junction region of the lower insulating substrate 200 at the same time. A metal having a good reflectivity is used for the conductive material, and generally Al, Cr, Mo, W, Ti, Ta, or alloy thereof is used for the same. After forming the reflecting plate 267 of the encapsulating junction region and the source/drain electrodes 261 and 265, a passivation layer 270 is deposited on the lower insulating substrate 200, and a via-hole 275 is formed on the passivation layer 270 to expose some portions of one of the source electrode 261 and the drain electrode 265, for example, some portions of the drain electrode 265.

After depositing a lower electrode material on the passivation layer 270 including the via-hole 275, the lower electrode is patterned to form a lower electrode 280 electrically connected to the drain electrode 265 through the via-hole 275. After forming the lower electrode 280, a pixel defining layer 290 is deposited on the entire surface of the lower insulating substrate 200 and patterned to form an opening portion 295 that exposes some portions of the lower electrode 280.

An organic layer 300 is then formed on the pixel defined layer 290 including the opening portion 295. And an upper electrode 310 is formed on the organic layer 300 over the entire surface of the lower insulating substrate 200 to form a light emitting element (LE) made up of the lower electrode 280, organic layer 300, and the upper electrode 310. The

lower insulating substrate 200 is then encapsulated to the upper substrate 320 by using a sealant 330 in the encapsulating junction region.

The sealant 330 is preferably a light-curing sealant, and more preferably a light curing sealant capable of being cured not only by exposure to light in an ultraviolet range but also to light in the visible range. 30Y-296G (three bond), XNR5516 (Nagase Ciba), electrolyte, or Kyoritsu are preferably used for the sealant 330.

In addition, the thickness "L" in FIG. 8 of the sealant 330 is a distance between the reflecting plate 267 and the upper substrate 320. This thickness L is preferably set to cause constructive interference in the light used to cure the sealant 330. Constructive interference is to occur between the incident light and the light reflected off the reflecting plate 267. The optimal distance L between the reflecting plate and the opposite substrate can be determined by the following equation:

$$L = \lambda/4 + (n-1)\lambda/2 \quad (n=1,2,3, \dots)$$

And ultraviolet rays or visible rays are then irradiated on the upper substrate 320 to cure the sealant 330. The optimal range for wavelength used to cure the sealant is from 200 nm to 700 nm. Another design consideration is that it is preferable to have at least 25% of the total surface area of the sealant 330 in contact with reflecting plate 267. As discussed earlier, it is preferable to form the reflecting plate 267 and the source/drain electrodes 261 and 265 at the same time to reduce the number of processing steps and to reduce manufacturing costs in the fourth embodiment. Alternatively, the reflecting plate 267 can be deposited and patterned at the same time as when the gate electrode 240 is formed. Alternatively, the reflecting plate 267 can be formed at the beginning of the process, before buffer layer 210 is formed on lower insulating substrate 200. Before forming the buffer layer 210, a material having good reflectivity, such as any one metal of Al, Mo, Ti, Ag and Mg, or an alloy containing at least one of these metals (i.e., Mo/Al/Mo, Ti/Al/Ti) may be deposited and patterned on the lower insulating substrate 200 to form the reflecting plate 267 in the encapsulating junction region of the display.

In another design consideration, the width of the reflecting plate 267 in FIG. 8 is illustrated to be larger than the contact area of the sealant 330, however, the width of the reflecting plate 267 may be formed to be smaller than the contact area contact area of the sealant 330. In such a scenario, the sealant 330 may contact lower insulating substrate 200.

The inclusion of the reflecting plate 267 in the design of the electro luminescent display attached to a light-cured sealant 330 in the edge or encapsulation junction region is advantageous for the following reason. Light used to cure the sealant 330 also exposes other portions of the electro luminescent display. This light used to cure the sealant 330 can damage other parts of the electro luminescent display. By placing a reflective plate in the encapsulation junction region of the display, less incident light energy is needed to cure the sealant because both the incident light and the reflected light can be used to cure the sealant. Therefore, the intensity of the incident light needed to cure the sealant is less if the reflecting plate is present. Therefore, because less incident light is needed to cure the sealant, less damage is sustained by the electro luminescent display during the curing process.

Turning now to FIGS. 9 and 10, FIGS. 9 and 10 illustrate top views of electro luminescent displays according to the fourth embodiment of the present invention. As is clearly illustrated in FIGS. 9 and 10, the width of the sealant 330 is greater than the width of the reflecting plate 267. Therefore, in

11

the designs illustrated in FIGS. 9 and 10, the sealant 330 maybe in contact with lower insulating substrate 200.

In FIG. 9, the reflecting plate 267 is formed as one continuous piece in the form of a closed square. Alternatively, in FIG. 10, the reflecting plate 267 is formed of four discrete portions disconnected from each other. It is to be appreciated that the reflecting plate 267 does not serve to conduct electricity, and thus having four discrete segments in FIG. 10 works just as well as one continuous closed piece in FIG. 9.

Fifth Embodiment

FIG. 11 is a cross-sectional view showing the encapsulating junction region of the organic electro luminescent display in accordance with a fifth embodiment of the invention. The organic electro luminescent display according to the fifth embodiment has a similar structure as that of the fourth embodiment except the location of the reflecting plate 267. The reflecting plate 267 in the fifth embodiment of the present invention is in an inside surface of upper substrate 320 instead of being on the inside surface of lower insulating substrate 200. In order to form the structure of FIG. 11, after forming the TFT and the light emitting element LE on the lower insulating substrate 200 as illustrated in FIG. 7, a metal thin layer is then deposited and patterned on the inner side of the upper substrate 320 to form the reflecting plate 267 in the encapsulating junction region. As in the fourth embodiment, the upper substrate 320 is bonded to the lower insulating substrate 200 by using the sealant 330 in the encapsulating junction region.

Sixth Embodiment

FIG. 12 is a cross sectional view showing an encapsulating junction region of the organic electro luminescent display in accordance with a sixth embodiment of the invention. The organic electro luminescent display according to the sixth embodiment has a similar structure as that of the fourth and fifth embodiments except for the location of the reflecting plate 267. In the sixth embodiment, the reflecting plate 267 is located on the outer side of lower insulating plate 200. In the sixth embodiment as in the fourth and the fifth embodiments, the reflecting plate is located only in the encapsulated junction region at the edges of the electro luminescent display.

In order to make the structure of FIG. 12, after forming the TFT and the light emitting element on the lower insulating substrate 200 as illustrated in FIG. 7, the upper substrate 320 is bonded to the lower insulating substrate 200 by using the sealant 330 in the encapsulating junction region. After encapsulating the upper substrate 320 to the lower insulating substrate 200, a metal thin layer is deposited and patterned on an outer side of the lower insulating substrate 200 to form the reflecting plate 267 in the encapsulating junction region.

Seventh Embodiment

FIG. 13 is a cross sectional view showing an encapsulating junction region of the organic electro luminescent display in accordance with a seventh embodiment of the invention. The organic electro luminescent display according to the seventh embodiment has a similar structure as that of the fourth embodiment but that the reflecting plate 267 is formed on an outer side of the upper insulating plate 320 as opposed to an inner side of lower insulating substrate 200.

In order to form the structure of FIG. 13, after forming the TFT and the light emitting element on the lower insulating substrate 200 as illustrated in FIG. 7, a thin metal layer is

12

deposited and patterned on the outer side of the upper substrate 320 to form the reflecting plate 267 in the encapsulating junction region. After forming the reflecting plate 267 in the encapsulating junction region on the outer side of the upper substrate 320, the upper substrate 320 is then bonded to the lower insulating substrate 200 by using the sealant 330 in the encapsulating junction region.

Eighth Embodiment

FIG. 14A and FIG. 14B are a cross sectional view showing an encapsulating junction region of the organic electro luminescent display in accordance with an eighth embodiment of the invention. The organic electro luminescent display according to the eighth embodiment has a similar structure as that of the fourth embodiment except that a waveguide 217 is formed on the inner side of lower insulating substrate instead of the reflecting plate 267. Preferably the wave guide is unevenness or a convex lens. FIG. 14A illustrates the wave guide 217 as unevenness. FIG. 14B illustrates wave guide 217 as a convex lens.

Referring to FIG. 14A and FIG. 14B, the wave guide 217 of the organic electro luminescent display according to the eighth embodiment is formed on the inner side of the encapsulating junction region of the lower insulating substrate 200 during the process of forming the TFT having the structure illustrated in FIG. 7 in the pixel portion. After depositing and patterning the buffer layer 210, the wave guide 217 is formed in a position corresponding to the encapsulating junction region of the lower insulating substrate 200.

Alternatively, the wave guide 217 may be formed simultaneous to the patterning the gate insulating layer 230 and after depositing the gate insulating layer 230. Alternatively, wave guide 217 can be formed simultaneous to the etching of the interlayer insulating layer 250 to form the contact holes 251 and 255. Alternatively, the wave guide 217 may be formed simultaneous to the etching of the passivation layer 270 to form the via-hole 275.

Another alternative is to form a multi-layered wave guide 217 that is formed simultaneous to the formation of the buffer layer 210, gate insulating layer 230, interlayer insulating layer 250, and passivation layer 270. Alternatively, wave guide 217 made out of material having the optical transmissivity may be formed in a separate process step separate from the process of forming the other layers in FIG. 7.

The wave guide 217 is formed by adjusting an angle in consideration of a refraction index of the incident light, and makes the incident light focused on the sealant 330 of the encapsulating junction region to be formed later by the refraction.

Ninth Embodiment

FIG. 15A and FIG. 15B are a cross-sectional view showing an encapsulating junction region of the organic electro luminescent display in accordance with a ninth embodiment of the invention. The organic electro luminescent display according to the ninth embodiment has the same structure in the pixel portion as that of the eighth embodiment except that the wave guide 217 is formed on an inner surface of the upper substrate 320 instead of on the inner surface of the lower insulating substrate. FIG. 15A illustrates wave guide 217 as unevenness and FIG. 15B illustrates wave guide 217 as a convex lens.

The method of forming the structure if FIG. 15A and FIG. 15B is as follows. After forming the TFT and the light emitting element on the lower insulating substrate 200, a material having optical transmissivity is deposited on the inner side of

the upper substrate 320. The material having the optical transmissivity is then patterned to form the wave guide 217 on the inner of the upper substrate 320 in the encapsulation junction region. After forming the wave guide 217 on the inner side of the encapsulating junction region in the upper substrate 320, the lower electrode 280, the organic layer 300, and the upper electrode 310 are then formed on the upper substrate 320.

Tenth Embodiment

FIG. 16A and FIG. 16B are a cross-sectional view illustrating an encapsulating junction region of the organic electro luminescent display in accordance with a tenth embodiment of the invention. The organic electro luminescent display according to the tenth embodiment has the TFT and the light emitting element shown in FIG. 7 in the pixel portion, and has two wave guides 217, one formed on the inner surface of the upper substrate 320 and one formed on the inner surface of the lower insulating substrate 200. FIG. 16A illustrates wave guide 217 as unevenness while FIG. 16B illustrates wave guide 217 as a convex lens.

The wave guide 217 is formed on the inner side lower insulating substrate 200 is formed according to the same processes as that described in the eighth embodiment of FIG. 14A and FIG. 14B. The wave guide 217 formed on the inner side upper substrate 320 is made according to a process described in the formation of the wave guide 217 in the discussion of FIGS. 15A and 15B (the ninth embodiment). That is, the lower electrode 280, the organic layer 300, and the upper electrode 310 are then formed on an inner surface of upper substrate 320 after waveguide 217 is formed in the inner surface of upper substrate 320.

In addition, in the above-mentioned embodiments of the invention, an organic electro luminescent display having enhanced curing efficiency is disclosed by using both a reflecting plate and a wave guide formed in the upper substrate 320 or the lower insulating substrate 200 either respectively or anti respectively. Alternatively, two reflecting plates may be used, one attached to a surface of the upper substrate 320 and one attached to a surface of lower insulating substrate 200. The reflecting plates formed on both sides of the organic electro luminescent display are preferably formed to have a mirror attached to.

According to the invention, auxiliary layers are formed to remove organic layers on the encapsulating junction region, so that the invention can provide an organic electro luminescent display capable of easily removing the organic layers formed on the encapsulating junction region during the process of forming organic layers. In addition, the invention can provide a method for fabricating the organic electro luminescent display with reduced damage in the pixel portion by removing the organic layers disposed on auxiliary layers by a laser instead of removing the organic layers directly formed on the substrate.

Furthermore, according to the invention, a reflecting plate is disposed in the encapsulating junction region, so that the light emitted from the light source is reflected by the reflecting plate for curing the sealant, thereby enhancing the curing state of the sealant and putting the encapsulation of the substrates in better condition. In addition, with the reflective plate, the curing time is reduced, resulting in less damage sustained in the pixel regions of the display.

While the invention has been described with reference to a particular embodiment, it is understood that the disclosure has been made for purpose of illustrating the invention by way of examples and is not limited to limit the scope of the inven-

tion. And one skilled in the art can make amend and change the invention without departing from the scope and spirit of the invention.

What is claimed is:

1. An organic electro luminescent display, comprising: a lower insulating substrate on which TFTs and light emitting elements are formed; an upper substrate attached to the lower insulating substrate; an encapsulating junction region adapted to encapsulate and attach the upper substrate to the lower insulating substrate via a sealant; and a reflecting plate arranged only in the encapsulating junction region at any one side of any one of the upper substrate and the lower insulating substrate.
2. The display of claim 1, the reflecting plate being formed on an inner side of one of the upper substrate and the lower insulating substrate, the reflecting plate facing the other of the upper substrate and the lower insulating substrate.
3. The display of claim 1, the reflecting plate being formed on an outer side of one of the upper substrate and the lower insulating substrate.
4. The display of claim 1, the sealant being an optical curing sealant.
5. The display of claim 4, the sealant being an optical curable sealant cured by exposure to light in either a visible ray range or an ultraviolet ray range.
6. The display of claim 1, the reflecting plate comprising a metal thin layer deposited on any one side of the upper substrate and the lower insulating substrate.
7. The display of claim 1, the reflecting plate comprising a mirror attached to the outer side of one of the upper substrate and the lower insulating substrate.
8. The display of claim 1, wherein a distance from the reflecting plate to a nearest surface of a substrate opposing the reflecting plate is designed so that curing light reflected off the reflective plate constructively interferes with curing light incident to the reflective plate.
9. The display of claim 1, the reflecting plate being a mirror.
10. An organic electro luminescent display, comprising: a lower insulating substrate on which a pixel portion is arranged; an upper substrate arranged over the lower insulating substrate; and a sealing material arranged between the upper substrate and the lower insulating substrate and adapted to seal the upper substrate to the lower insulating substrate, wherein a metal layer is arranged between the lower insulating substrate and the sealing material, wherein the sealing material is formed along the peripheries of the substrates and not in the pixel portion of the display, and wherein the metal layer is formed coextensively along with the sealing material and is of the shape of a closed polygon.
11. The display of claim 10, wherein the metal layer is formed discontinuously in separate unconnected pieces around a perimeter of the display and along the sealing material.
12. The display of claim 10, the metal layer comprising a material being selected from the group consisting of Al, Mo, Ti, Ag, Mg and an alloy containing at least one of Al, Mo, Ti, Ag and Mg.
13. The display of claim 10, wherein at least 25% of the total surface area of the sealing material is in contact with said metal layer.

15

14. An organic electro luminescent display, comprising:
a lower insulating substrate on which a pixel portion is
formed;
an upper substrate arranged on the lower insulating sub-
strate; and
a sealing material arranged between the upper substrate
and the lower insulating substrate, the sealing material
being adapted to attach the upper substrate to the lower
insulating substrate, the sealing material being arranged
along peripheries of the substrates and outside of the
pixel portion; and
a reflecting plate arranged between the lower insulating
substrate and the sealing material, wherein the reflecting

16

plate is arranged to be coextensive with the sealing mate-
rial and is in the shape of a closed polygon.
15. The display of claim 14, the reflecting plate being a
plurality of separate unconnected segments arranged essen-
tially along the sealing material.
16. The display of claim 14, wherein at least 25% of an
outer surface of the sealing material is in contact with the
reflecting plate.
17. The display of claim 14, the reflecting plate being a
mirror.
18. The display of claim 17, the metal being selected from
a group consisting of Al, Mo, Ti, Ag, Mg and an alloy con-
taining at least one metal of Al, Mo, Ti, Ag and Mg.

* * * * *

专利名称(译)	有机电致发光显示器及其制造方法		
公开(公告)号	US7521857	公开(公告)日	2009-04-21
申请号	US11/512091	申请日	2006-08-30
[标]申请(专利权)人(译)	KANG TAE MIN SONG MYUNG WON 李圣TAEK 朴镇宇 KIM HUN		
申请(专利权)人(译)	KANG TAE-MIN 宋李明博WON 李圣泽 朴镇宇 KIM HUN		
当前申请(专利权)人(译)	三星移动显示器有限公司.		
[标]发明人	KANG TAE MIN SONG MYUNG WON LEE SEONG TAEK PARK JIN WOO KIM HUN		
发明人	KANG, TAE-MIN SONG, MYUNG-WON LEE, SEONG-TAEK PARK, JIN-WOO KIM, HUN		
IPC分类号	H05B33/00 H01L27/32 H01L51/52 H01L51/56 H05B33/04 H05B33/10 H05B33/12 H05B33/22		
CPC分类号	H01L51/5237 H01L51/56 H01L27/3244 H01L27/3276 H01L27/3281 H01L27/3295 H01L51/0003 H01L51/0009 H01L27/3246 H01L51/5246		
审查员(译)	帕特尔ASHOK		
其他公开文献	US20060290273A1		
外部链接	Espacenet USPTO		

摘要(译)

一种有机电致发光显示器，在阴极接触和封装结区域上具有辅助层，以容易地去除结的聚合物有机层，以及制造该有机电致发光显示器的方法。有机电致发光显示器具有形成在下绝缘基板上的第一电极，形成为使得第一电极的一些部分在下绝缘基板的整个表面上开口的像素限定层，形成在下绝缘基板的开口上的有机发光层。第一电极，形成在有机发光层上的第二电极，用于封装第一电极，有机发光层和第二电极的上基板，以及形成在下绝缘基板的阴极接触和封装结区域上的辅助层。

